

Eye Anchor Instructions

Do-it-Yourself protection for most outdoor structures or possessions.

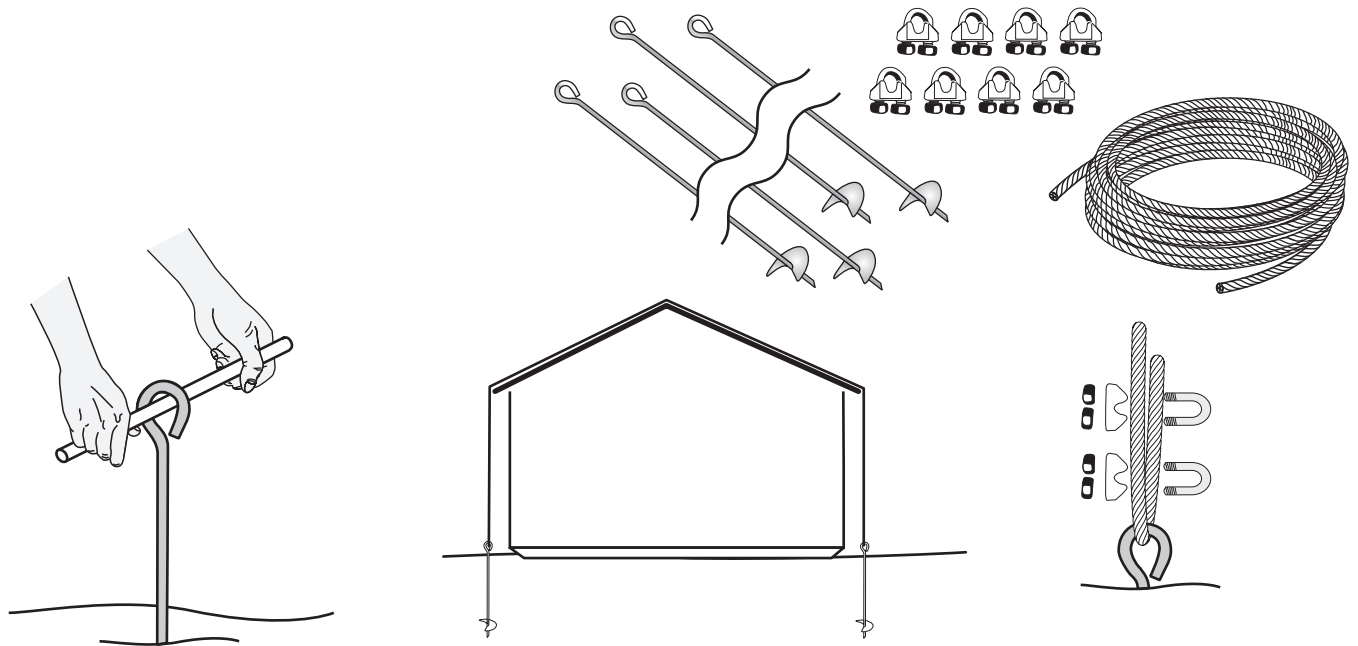

1. Install ground anchors as close to the building as possible at all four corners.
 - A. Install anchors using a straight rod to turn (screw) anchor into the ground.
 - B. A starter hole, up to 1/3 of the anchor length can be used to start anchor into the ground. Once the anchor eye is level with the ground, backfill the soil and pack area around the anchor eye.
 - C. Anchor eye should be just above soil level.
2. Cable can be secured to the building using the following methods.
 - A. Attach one end of the cable to an anchor using the wire rope clips. Cable goes thru the anchor eye and is clamped together using the wire clip. Place the cable over the roof of the opposite anchor, loop cable thru anchor eye. Cut cable to have enough to attach to the anchor. Pull cable tight, attach wire rope clips (2), tighten nuts. Repeat for other side
 - B. Attach cable to the side wall studs. Additional Eyebolts and Wire Rope Clips and hardware may be required.

NOTE:

These instructions are for suggested attachment to small shed not located in high wind areas. For more detailed anchor requirements, see the wind zone charts for your area. You may need additional anchors, cable, wire clamps or other forms of anchor attachments to the shed to meet local or state requirements.



Rigging.com

Calculation Chart Instructions

Example:

Wind Zone II chart shows 12' x 18' building:

- Looking in 12' column - Use lowest value in the 12' column for the number of anchors 3
- Looking in 18' column - find the corresponding width of 12' to obtain the number of anchors for the 18' side 5
(if building width exceeds the widths shown in the Building Width column, use the lowest number of anchors in the corresponding Building Width column)

Note*

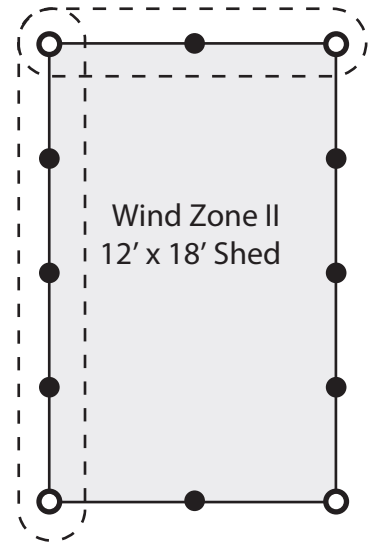

*NOTE: Anchors at the corners shall be counted only once in the quantity required for each side or face of building.

- Total Anchors needed per 12' x 18' shed in Wind Zone II.....12

Building Width (ft.)	Building Length (ft.)														
	5	6	8	10	12	14	16	18	20	22	24	26	28	30	32
5	2	2	3	4	4	5	6	6	7	7	8	9	9	10	11
6	-	2	3	3	4	5	5	6	7	7	8	9	9	10	10
7	-	-	3	3	4	4	5	5	6	6	7	7	8	8	9
8	-	-	3	3	4	4	5	5	6	6	7	7	8	8	9
10	-	-	-	3	3	4	4	5	6	6	7	7	8	8	9
12	-	-	-	-	3	4	4	5	6	6	7	7	8	8	9
14	-	-	-	-	1	4	5	5	6	7	7	8	8	9	9
16	-	-	-	-	-	5	5	6	6	7	7	8	8	9	9
18	-	-	-	-	-	-	6	6	7	7	8	8	9	9	9

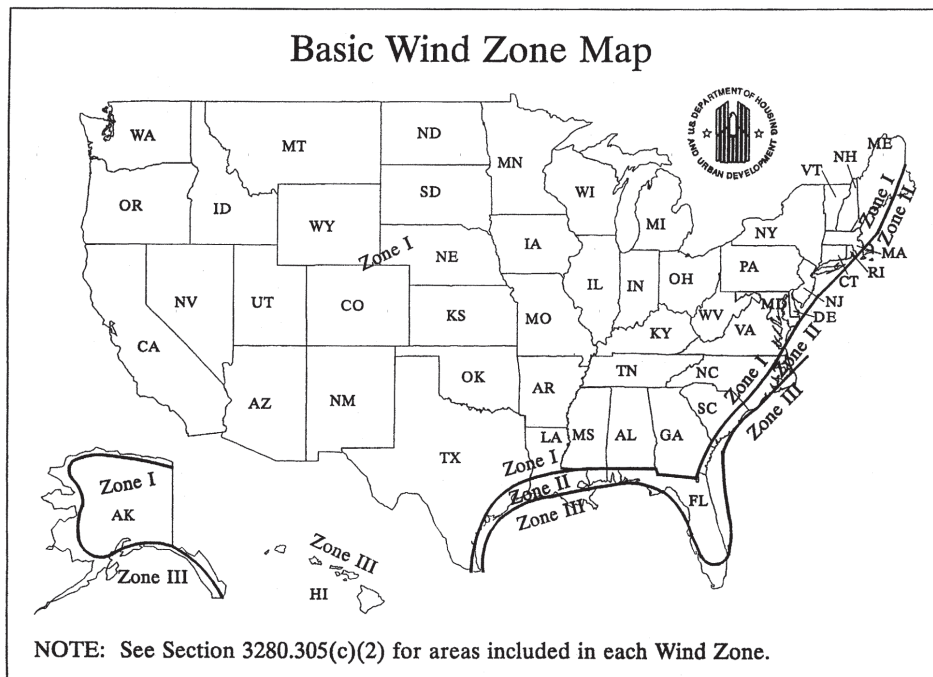

S 3280.305

24 CFR Ch. XX (4-1-06 Edition)

E-Rigging.com

WIND ZONE I

Wind Zone: 1

Anchor Description: 1/2" x 15" Eye Anchor with 4" Helix
Model Number: 94656005

Building Width (ft.)	Building Length (ft.)														
	5	6	8	10	12	14	16	18	20	22	24	26	28	30	32
5	2	2	2	3	3	4	4	5	5	6	6	7	7	8	8
6	-	2	2	3	3	4	4	5	5	6	6	7	7	7	8
7	-	2	2	3	3	4	4	5	5	6	6	6	7	7	8
8	-	-	2	3	3	4	4	5	5	6	6	6	7	7	8
10	-	-	-	3	3	4	4	5	5	6	6	7	7	8	8
12	-	-	-	-	4	4	5	5	6	6	7	7	8	8	9
14	-	-	-	-	-	4	5	6	6	7	7	8	8	9	10
16	-	-	-	-	-	-	5	6	7	7	8	8	9	10	10
18	-	-	-	-	-	-	-	6	7	8	8	9	10	10	11

WIND ZONE II

Wind Zone: 2

Anchor Description: 1/2" x 15" Eye Anchor with 4" Helix
Model Number: 94656005

Building Width (ft.)	Building Length (ft.)														
	5	6	8	10	12	14	16	18	20	22	24	26	28	30	32
5	5	6	7	9	11	13	14	16	18	19	21	23	25	26	28
6	-	5	7	8	10	11	13	14	16	18	19	21	22	24	25
7	-	5	6	8	9	11	12	13	15	16	18	19	21	22	24
8	-	-	6	7	9	10	12	13	14	16	17	18	20	21	23
10	-	-	-	7	8	10	11	12	14	15	16	18	19	20	22
12	-	-	-	-	8	10	11	12	14	15	16	18	19	20	22
14	-	-	-	-	-	10	11	13	14	16	17	18	20	21	22
16	-	-	-	-	-	-	12	13	15	16	18	19	21	22	23
18	-	-	-	-	-	-	-	14	16	17	19	20	22	23	25

WIND ZONE III

Wind Zone: 3

Anchor Description: 1/2" x 15" Eye Anchor with 4" Helix
Model Number: 94656005

Building Width (ft.)	Building Length (ft.)														
	5	6	8	10	12	14	16	18	20	22	24	26	28	30	32
5	6	7	9	11	13	15	17	19	21	23	25	27	29	32	34
6	-	6	8	10	12	14	15	17	19	21	23	25	27	28	30
7	-	6	7	9	11	13	14	16	18	20	21	23	25	27	28
8	-	-	7	9	10	12	14	15	17	19	20	22	24	25	27
10	-	-	-	8	10	12	13	15	16	18	20	21	23	24	26
12	-	-	-	-	10	12	13	15	17	18	20	21	23	25	26
14	-	-	-	-	-	12	14	15	17	19	20	22	24	25	27
16	-	-	-	-	-	-	14	16	18	19	21	23	25	26	28
18	-	-	-	-	-	-	-	17	19	20	22	24	26	28	29

Notes:

- 1) Maximum 102" building height.
- 2) One anchor shall be placed at each corner of building.
- 3) Any required anchors between corners shall be spaced equidistant apart from each other.
- 4) Number of anchors required per side shall be determined by finding quantities listed in columns.

